

RTU100

HARDWARE MANUAL

- RTU100
RTU Series

CONTENTS

FIGURES LIST	2
Preface.....	3
About Mikrodev	4
WARNING!.....	5
1 RTU100 GENERAL INFORMATION	6
1.1 GB0 Board Type Physical Interfaces.....	6
1.2 General Device Specifications	7
2 INSTALLATION INFORMATION.....	8
2.1 Rail Installation	8
2.2 Expansion Installation	9
3 CONNECTION DIAGRAMS	10
3.1 Supply Connection.....	10
3.2 Digital Inputs.....	11
3.3 Digital Outputs.....	12
3.4 Analog Inputs	13
3.5 RS485 SERIAL PORT	14

FIGURES LIST



Figure 1 GB0 Board Type Connector and Physical Interface.....	6
Figure 2 Mounting.....	8
Figure 3 Expansion Installation.....	9
Figure 4 Power Connection Diagram.....	10
Figure 5 Digital Input Connection Diagram.....	11
Figure 6 Digital Output Connection Diagram.....	12
Figure 7 Analog Input Connection Diagram	13
Figure 8 RS485 Serial Port Connection Diagram	14

Preface



Mikrodev RTU100 series RTUs can monitor and control Intelligent Electrical Devices (protection relays, reclosing cutters, energy and quality analyzers ... etc) via industry standard protocols like IEC 61850, Modbus TCP and Modbus RTU. They can also communicate with SCADA or control center software via IEC 60870, DNP3 and MODBUS TCP protocols. With its easy, flexible and fast programming capabilities and expandable I/O capability up to 1024 points, Mikrodev RTU products are preferred for electrical applications. Mikrodev RTU100 Series RTUs are programmed mainly using Function Block Diagram - FBD language which is defined in IEC 61131-3 standard. Thanks to programming with FBD language, you can develop applications easily and quickly with drag and drop logic.

Please follow our website www.mikrodev.com for the up to date version of the document.

About Mikrodev



Since 2006, MIKRODEV has been developing and manufacturing industrial control and communication products. MIKRODEV serves the system integrators in the public and private sector, OEM and end users.

Our products are manufactured complying with the quality standards required by the industrial automation industry and the quality of our products are proved on the field for many years

MIKRODEV is one of the few companies in the world that has its own designed IEC 61131-3 compliant library for its programmable logic control devices. In addition, the open, flexible, programmable SCADA solution developed by MIKRODEV is also available to customers.

MIKRODEV products' performance and wide range of applications make them possible for customers to achieve faster, simplified and cost-effective results.

WARNING!

- ✓ Please take care of the following issues when using Mikrodev devices.
- ✓ Since the unit operates with 24 VDC (12-36 VDC) voltage, you should take care of the voltage level that the unit is connected to. If a voltage above this voltage level is applied, the device may be damaged and may be out of warranty.
- ✓ Make sure that the energy connection of your device is connected to the ground or to a properly grounded terminal.
- ✓ Make sure that the environment in which your device is being used is free of moisture, electric shock, vibration and dust.
- ✓ Pay attention to the supply voltage and the connections of the product. Mikrodev is not responsible for any issues due to power failure since there is no auxiliary supply (UPS) on the device.
- ✓ The fuse to be used must be a FF super fast type and current limit value 1A.
- ✓ Do not use the device under conditions other than the environmental conditions specified in the "Electrical Specifications" section (humidity, dust, liquid and temperature, etc.)
- ✓ Removing the warranty label on the product or removing the protective case will void the warranty.
- ✓ Products that are damaged, boxes have been changed and other brand labels are affixed are not covered by the warranty.
- ✓ The appliance must not be cleaned with solvents (thinner, benzine, acid etc.) or with abrasive cleaning agents.
- ✓ Only dry cloth should be used when cleaning the appliance.
- ✓ Do not open the device by removing the case of the appliance, do not interfere with the electronic components and circuits. There is no user-replaceable part inside the device.
- ✓ If there is a problem or malfunction on your device, it should only be repaired by an authorized service. Installation and electrical connections must be made by technical personnel in accordance with the instructions in the operating manual.

Failure to comply with these rules may result in death, serious injury or property damage

1 RTU100 GENERAL INFORMATION

1.1 GB0 Board Type Physical Interfaces

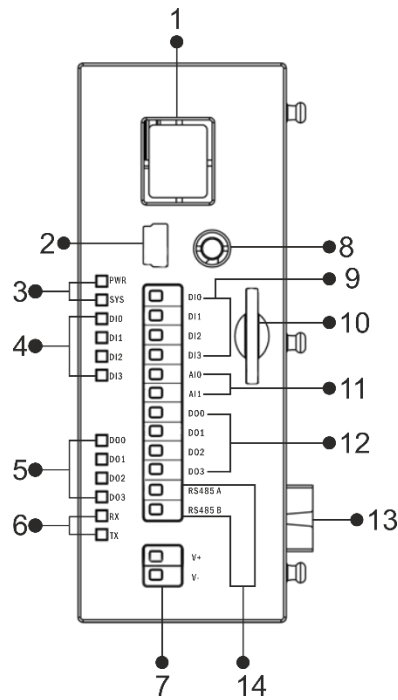

Figure 1 GB0 Board Type Connector and Physical Interface

1	Ethernet Port	8	Antenna Connection
2	USB Port	9	Digital Input Connections
3	System Power /Running LED	10	SIM Card Slot
4	Digital Input Status Information	11	Analog Input Connections
5	Digital Output Status Information	12	Digital Output Connections
6	Protocol Data Transfer LED	13	Expansion Connector
7	Device Power (V+/V-) Connection	14	RS485 Connections

1.2 General Device Specifications

SPECIFICATION	ITEM	DESCRIPTION
Processor	Processor Architecture	ARM Cortex M4
	Addressing Architecture	Little Endian Addressing
Electrical	Supply	24 VDC (12-36VDC)
	Power	<10W @ 24V DC
	Real Time Clock	Integrated
Input / Output	Board Type	GB0
	Digital Input	4 Channel, PNP
	Digital Output*	4 Channel, 0.5A@24VDC per Channel, PNP
	Analog Input	2 Channel, 0-20 mA, 4-20 mA
Environmental Conditions	Operating Temperature	-20...+60 C
	Storage Temperature	-40...+85 C
	Humidity	5..95 RH
Memory	Retentive Memory	4 KB, 128 Block/Register
	Program Memory	4 MBit
Communication Ports	Ethernet Port	10/100 Mbps
	RS485	1 Port, 3 Kv ESD Protection
	USB	1 Port, Mini USB Type B
Wireless Communication**	GSM / GPRS or GSM / LTE	Quad-Band 850/900/1800/1900 MHz or LTE
Expansion Capacity	Din RAIL Type- CANBUS Expansion Modules	Up to 512 I/O Points

**The digital outputs are 125 mA per channel in production prior to serial number 761800.*

***Optional selection*

2 INSTALLATION INFORMATION

2.1 Rail Installation

DIN Rail Mountage

First, the upper part of the device is mounted on the DIN rail. Then, with the help of the springs behind the device, when a lightly force is applied to the lower part, the device locates into the DIN rail easily and the montage is completed. (See Figure 2)

DIN Rail Demountage

To demount the device, firstly it is pulled from the bottom using flexibility of the spring, the device is removed from the DIN Rail and the demounting is completed.

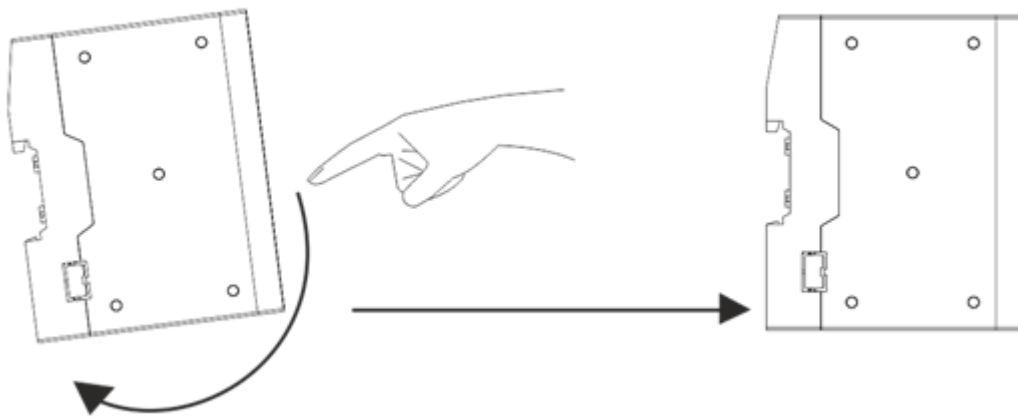

Figure 2 Mounting

2.2 Expansion Installation

The RTU100 product and its extensions are mounted by sliding over the rail in such a way that the connectors corresponds.

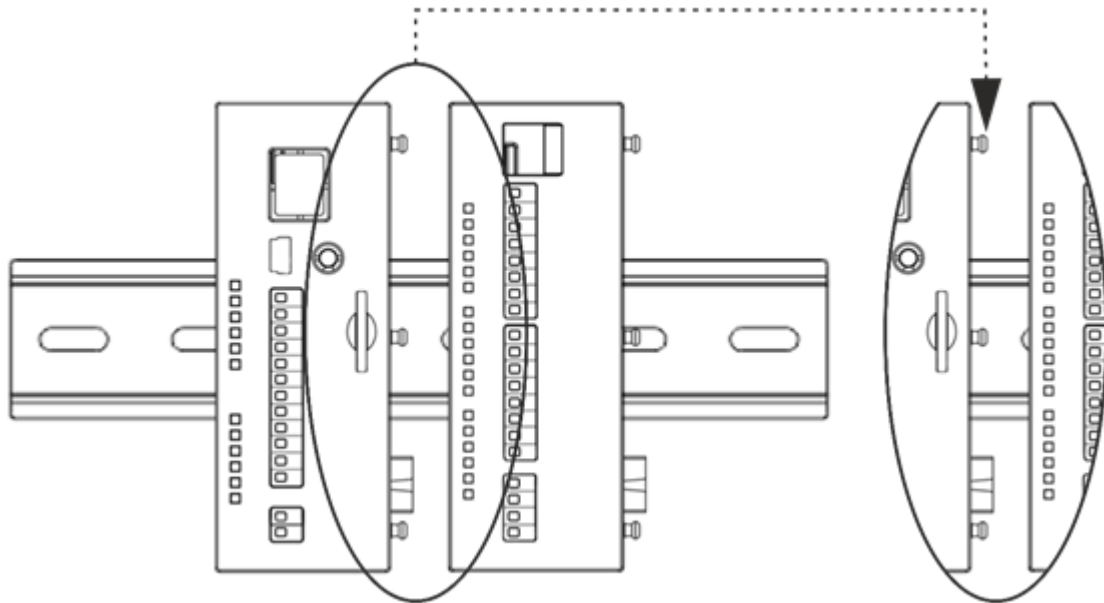

Figure 3 Expansion Installation

3 CONNECTION DIAGRAMS

3.1 Supply Connection

Board Type:	GB0
Supply:	12-36 VDC, Protected
Power:	< 13 W

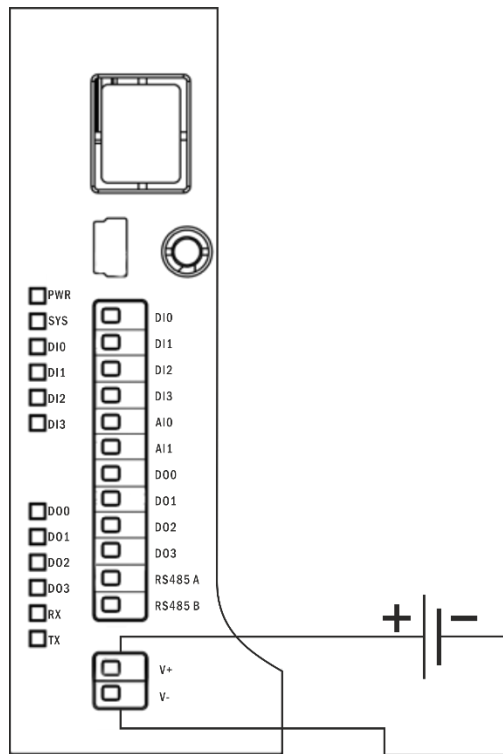

Figure 4 Power Connection Diagram

3.2 Digital Inputs

Board Type:	GB0
Module Input:	4 Channel, PNP
Voltage Range:	0-36 VDC
ON Voltage Level:	12-36 VDC
OFF Voltage Level:	0-10 VDC
Input Impedance:	>2M
Isolation:	Optical
OFF to ON Response:	20 us
ON to OFF Response:	90 us
Fast Counter Inputs:	DI0, DI1, DI2, DI3
Fast Counter Inputs Max. Frequency:	200 kHz

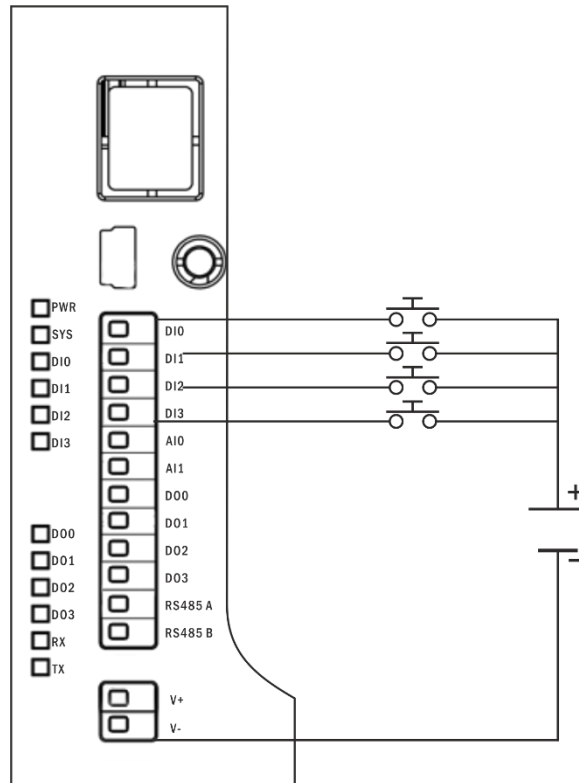

Figure 5 Digital Input Connection Diagram

3.3 Digital Outputs

Board Type:	GB0
Module Output:	4 Channel, Mosfet Output
Voltage Range:	12-36V DC
Max. Output Current:	0.5A@24VDC per Channel
Isolation:	Optical
Pulse Width Modulation Output and Pulse Train Output:	DO0, DO1, DO2, DO3
Pulse Train Output Max. Frequency(PTO):	50 kHz
Pulse Width Modulation Output Max. Frequency(PWM):	65 kHz

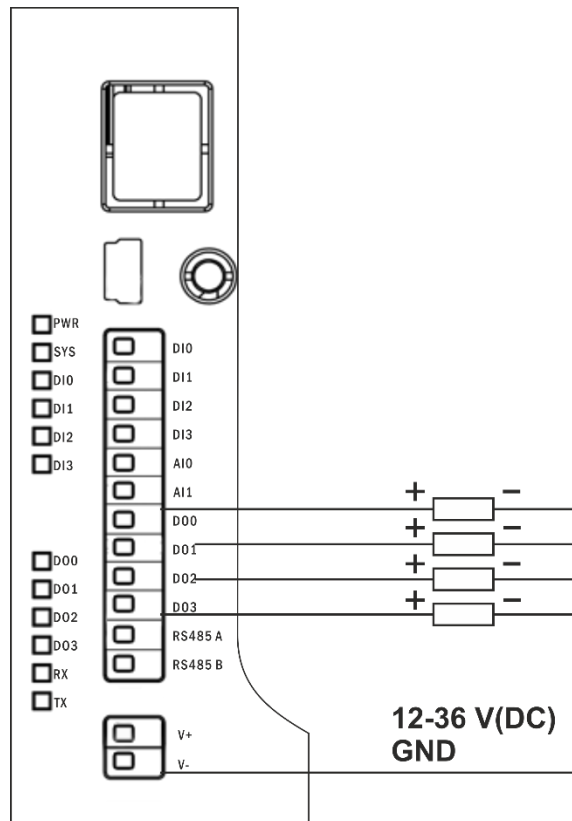

Figure 6 Digital Output Connection Diagram

3.4 Analog Inputs

Board Type:	GB0
Module Input:	2 Channel
Analog Input Type	0-20 mA, 4-20 mA
Analog Input Resolution:	12 Bit
Analog Input Precision:	%1 Precision
Common Input GND:	1 GND (4 Point / Common)

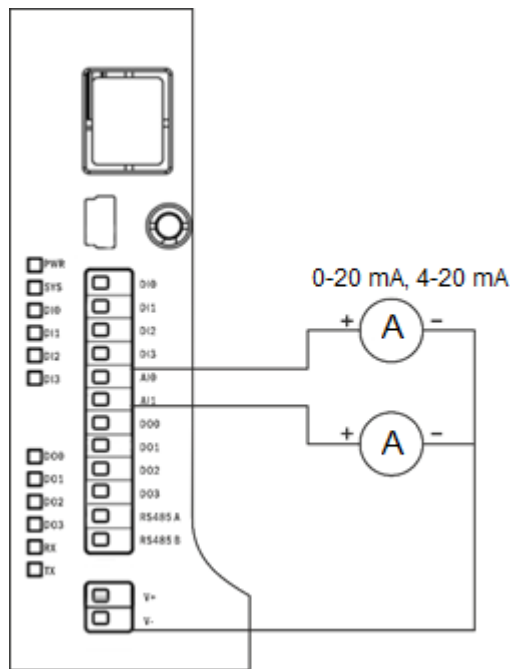

Figure 7 Analog Input Connection Diagram

3.5 RS485 SERIAL PORT

Board Type:	GB0
RS485 Port Count:	1 Port
Maximum Slave Counts:	Limited to Hardware
Isolation:	ESD Protection, 8 KV Direct, 25 kV Air Discharge
Communication Distance:	1000 m
Data Bits:	7-8
Stop Bits:	1-2
Parity:	None-Even-Odd
Baudrate:	300 bps to 200 kbps

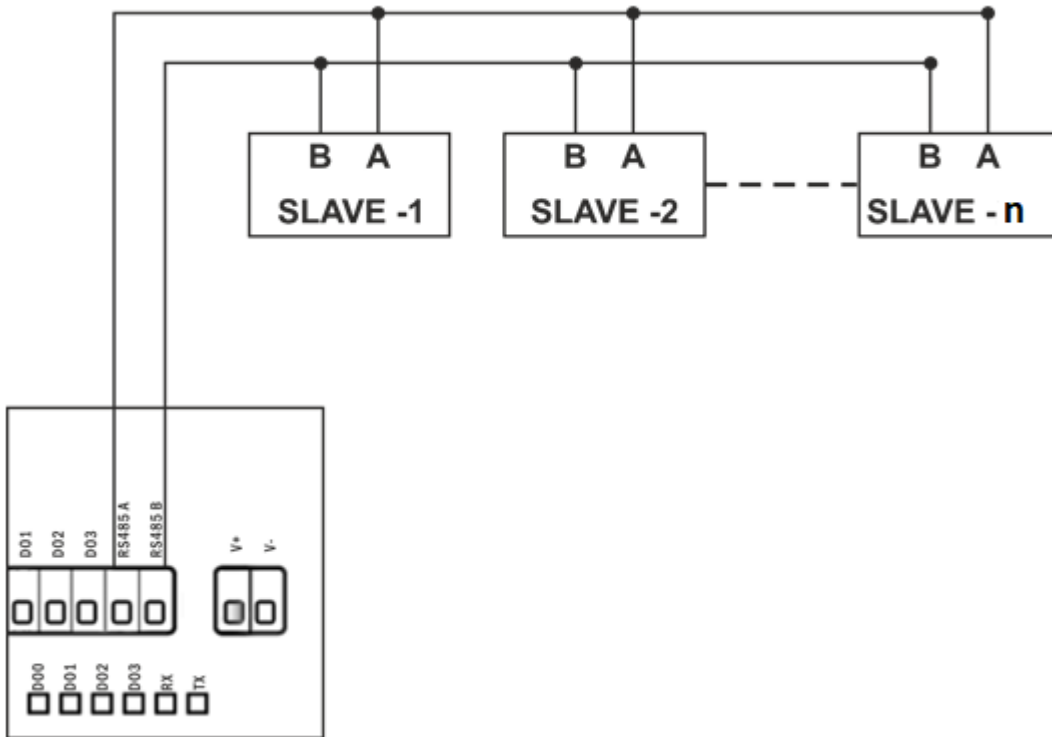

Figure 8 RS485 Serial Port Connection Diagram