

XIO110 EXPANSION FAMILY HARDWARE MANUAL

- XIO110-E0N-GD6-B2000 (8 Digital Input)
- XIO110-E0N-GD0-B2000 (16 Digital Input)
- XIO110-E0N-GD7-B4000 (8 Digital Output)
- XIO110-E0N-GD1-B4000 (16 Digital Output)
- XIO110-E0N-GD8-B6000 (8 Digital Input, 8 Digital Output)
- XIO110-E0N-GD2-B0401 (8 Analog Input, 0-20 mA, 0-10 V)
- XIO110-E0N-GD3-B0000 (8 Analog Output, 0-20 mA)
- XIO110-E0N-GD3-B0800 (8 Analog Output, 0-10 V)
- XIO110-E0N-GD9-B0000 (4 Analog Input, 4 Analog Output, 0-20 mA)
- XIO110-E0N-GD9-B0900 (4 Analog Input, 4 Analog Output, 0-10 V)
- XIO110-E0N-GD4-B0000 (6 RTD Input, PT1000)
- XIO110-E0N-GDA-B0000 (1 DALI BUS)
- XIO110-E0N-GDX-B0000 (END Module)

CONTENT

FIGURES LIST.....	3
Preface.....	4
About Mikrodev.....	5
WARNING!.....	6
Mounting Information.....	7
1 XIO110 DIGITAL INPUT EXPANSION MODULES	8
1.1 GENERAL INFORMATION	8
1.2 CONNECTION DIAGRAM	10
2 XIO110 DIGITAL OUTPUT EXPANSION MODULES.....	12
2.1 GENERAL INFORMATION	12
2.2 CONNECTION DIAGRAM	14
3 XIO110 DIGITAL INPUT OUTPUT EXPANSION MODULES	16
3.1 GENERAL INFORMATION	16
3.2 CONNECTION DIAGRAM	17
4 XIO110 ANALOG INPUT EXPANSION MODULES	19
4.1 GENERAL INFORMATION	19
4.2 CONNECTION DIAGRAM	20
5 XIO110 ANALOG OUTPUT EXPANSION MODULES.....	22
5.1 GENERAL INFORMATION	22
5.2 CONNECTION DIAGRAM	23
6 XIO110 ANALOG INPUT OUTPUT EXPANSION MODULES	25
6.1 GENERAL INFORMATION	25
6.2 CONNECTION DIAGRAM	26
7 XIO110 RTD INPUT(PT100/PT1000) EXPANSION MODULES	28
7.1 GENERAL INFORMATION	28
7.2 CONNECTION DIAGRAM	29
8 XIO110 DALI EXPANSION MODULES	31
8.1 GENERAL INFORMATION	31
8.2 CONNECTION DIAGRAM	32

9	XIO110 END MODULE	35
9.1	GENERAL INFORMATION	35
9.2	CONNECTION DIAGRAM	36

FIGURES LIST



Figure 1 DIN Rail Mounting	7
Figure 2 Expansion Module Mounting	7
Figure 3 GD6 Board Type Connector and Physical Interfaces	8
Figure 4 GD0 Board Type Connector and Physical Interfaces	9
Figure 5 Digital Input Expansion Module Power Connection Diagram	10
Figure 6 Digital Input Expansion Module Connection Diagram	11
Figure 7 GD7 Board Type Connector and Physical Interfaces	12
Figure 8 GD1 Board Type Connector and Physical Interfaces	13
Figure 9 Digital Output Expansion Module Power Connection Diagram	14
Figure 10 Digital Output Expansion Module Connection Diagram	15
Figure 11 GD8 Board Type Connector and Physical Interfaces	16
Figure 12 Digital Input Output Expansion Module Power Connection Diagram	17
Figure 13 Digital Input Output Expansion Module Connection Diagram	18
Figure 14 GD2 Board Type Connector and Physical Interfaces	19
Figure 15 Analog Input Expansion Module Power Connection Diagram	20
Figure 16 Analog Input Expansion Module Connection Diagram	21
Figure 17 GD3 Board Type Connector and Physical Interfaces	22
Figure 18 Analog Output Expansion Module Power Connection Diagram	23
Figure 19 Analog Output Expansion Module Connection Diagram	24
Figure 20 GD9 Board Type Connector and Physical Interfaces	25
Figure 21 Analog Input Output Expansion Module Power Connection Diagram	26
Figure 22 Analog Input Output Expansion Module Connection Diagram	27
Figure 23 GD4 Board Type Connector and Physical Interfaces	28
Figure 24 RTD Input Expansion Module Power Connection Diagram	29
Figure 25 RTD Input Expansion Module Connection Diagram	30
Figure 26 GDA Board Type Connector and Physical Interfaces	31
Figure 27 DALI Expansion Module Power Connection Diagram	32
Figure 28 DALI Expansion Module Connection Diagram	33
Figure 29 DALI Current-Limited Power Output Connection	34
Figure 30 GDX Board Type Connector and Physical Interfaces	35
Figure 31 End Module Canbus Connection Diagram 1	36
Figure 32 End Module Canbus Connection Diagram 2	37

Preface



Mikrodev XIO110 series expansion modules are used together with MP110 PLC series and DM100 Remote Terminal Unit series. There are 14 different types of XIO110 expansion modules:

- XIO110-E0N-GD6-B2000 (8 Digital Input)
- XIO110-E0N-GD0-B2000 (16 Digital Input)
- XIO110-E0N-GD7-B4000 (8 Digital Output)
- XIO110-E0N-GD1-B4000 (16 Digital Output)
- XIO110-E0N-GD8-B6000 (8 Digital Input, 8 Digital Output)
- XIO110-E0N-GD2-B0401 (8 Analog Input, 0-20 mA, 0-10 V)
- XIO110-E0N-GD3-B0000 (8 Analog Output, 0-20 mA)
- XIO110-E0N-GD3-B0800 (8 Analog Output, 0-10 V)
- XIO110-E0N-GD9-B0000 (4 Analog Input, 4 Analog Output, 0-20 mA)
- XIO110-E0N-GD9-B0900 (4 Analog Input, 4 Analog Output, 0-10 V)
- XIO110-E0N-GD4-B0000 (6 RTD Input, PT1000)
- XIO110-E0N-GDA-B0000 (1 DALI BUS)
- XIO110-E0N-GDX-B0000 (END Module)

This document describes the hardware features of XIO110 series devices.

Please follow our website www.mikrodev.com for the up to date version of the document.

About Mikrodev



Since 2006, MIKRODEV has been developing and manufacturing industrial control and communication products. MIKRODEV serves the system integrators in the public and private sector, OEM and end users.

Our products are manufactured complying with the quality standards required by the industrial automation industry and the quality of our products are proved on the field for many years

MIKRODEV is one of the few companies in the world that has its own designed IEC 61131-3 compliant library for its programmable logic control devices. In addition, the open, flexible, programmable SCADA solution developed by MIKRODEV is also available to customers.

MIKRODEV products' performance and wide range of applications make them possible for customers to achieve faster, simplified and cost-effective results.

WARNING!

- ✓ Please take care of the following issues when using Mikrodev devices.
- ✓ Since the unit operates with 24 VDC (12-36 VDC) voltage, you should take care of the voltage level that the unit is connected to. If a voltage above this voltage level is applied, the device may be damaged and may be out of warranty.
- ✓ Make sure that the energy connection of your device is connected to the ground or to a properly grounded terminal.
- ✓ Make sure that the environment in which your device is being used is free of moisture, electric shock, vibration and dust.
- ✓ Pay attention to the supply voltage and the connections of the product. Mikrodev is not responsible for any issues due to power failure since there is no auxiliary supply (UPS) on the device.
- ✓ The fuse to be used must be a FF super fast type and current limit value 1A.
- ✓ Do not use the device under conditions other than the environmental conditions specified in the "Electrical Specifications" section (humidity, dust, liquid and temperature, etc.)
- ✓ Removing the warranty label on the product or removing the protective case will void the warranty.
- ✓ Products that are damaged, boxes have been changed and other brand labels are affixed are not covered by the warranty.
- ✓ The appliance must not be cleaned with solvents (thinner, benzine, acid etc.) or with abrasive cleaning agents.
- ✓ Only dry cloth should be used when cleaning the appliance.
- ✓ Do not open the device by removing the case of the appliance, do not interfere with the electronic components and circuits. There is no user-replaceable part inside the device.
- ✓ If there is a problem or malfunction on your device, it should only be repaired by an authorized service. Installation and electrical connections must be made by technical personnel in accordance with the instructions in the operating manual.

Failure to comply with these rules may result in death, serious injury or property damage

Mounting Information

DIN Rail Mounting

First, the upper part of the device is mounted on the DIN rail. Then, with the help of the springs behind the device, when a lightly force is applied to the lower part, the device locates into the DIN rail easily and the montage is completed. (See Figure 1)

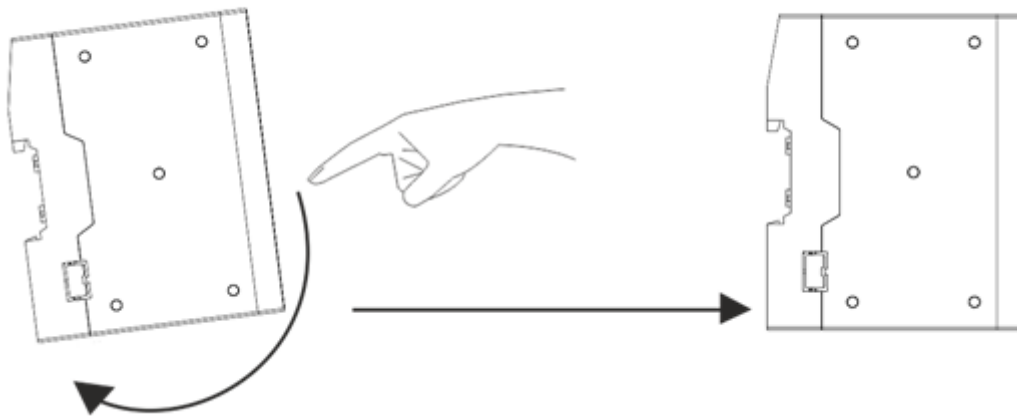

Figure 1 DIN Rail Mounting

Expansion Installation

Assembly between MP110 series PLC or RIO110 series remote I/O products and XIO110 series expansion modules is carried out by sliding the tabs over the rail so that the tabs overlap each other.

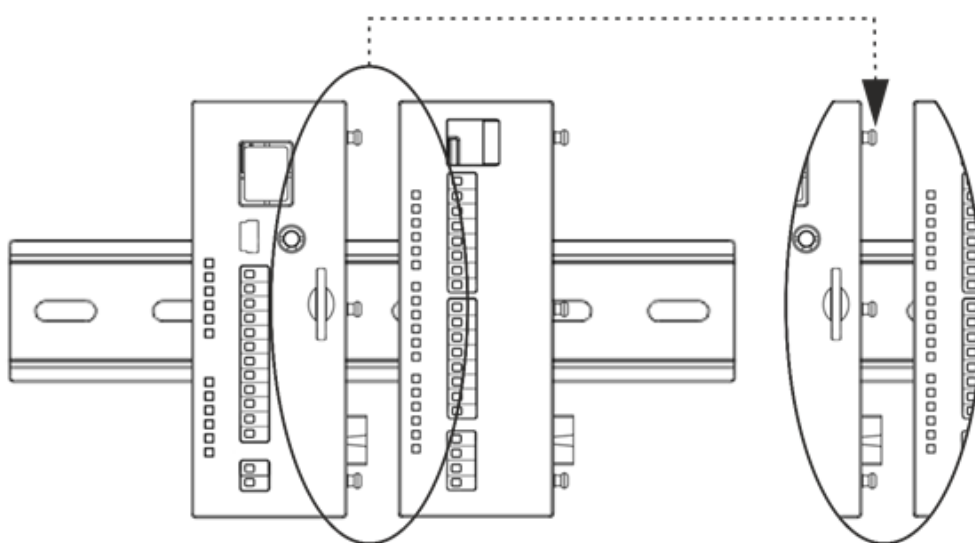

Figure 2 Expansion Module Mounting

1 XIO110 DIGITAL INPUT EXPANSION MODULES

1.1 GENERAL INFORMATION

1.1.1 GD6 Board Type(8 Digital Input) Physical Interfaces

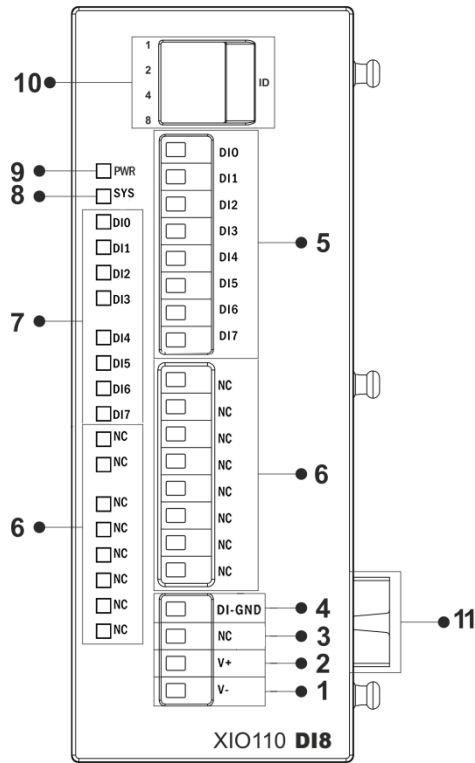

Figure 3 GD6 Board Type Connector and Physical Interfaces

1	Device Power (V-) Connection
2	Device Power (V+) Connection
3	N/A
4	Digital Input Ground Connection
5	Digital Input Connections
6	N/A
7	Digital Input Status Information LED
8	System Running LED
9	System Power LED
10	ID Assign Switch
11	Expansion Connector

1.1.2 GD0 Board Type(16 Digital Input) Physical Interfaces

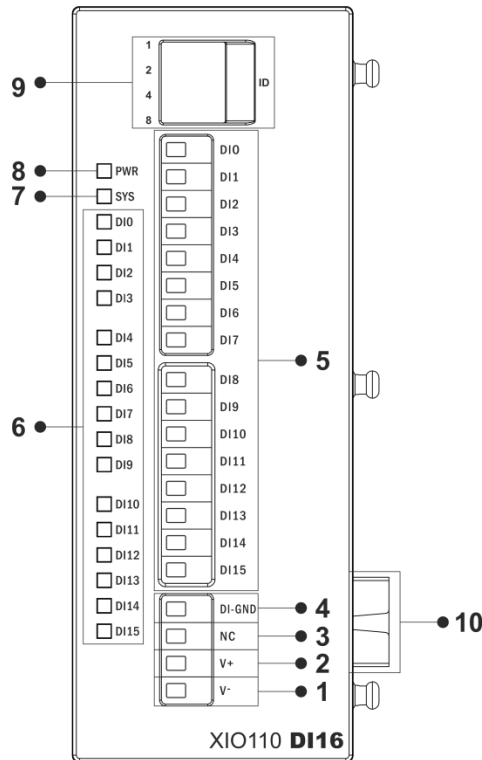

Figure 4 GD0 Board Type Connector and Physical Interfaces

1	Device Power (V-) Connection
2	Device Power (V+) Connection
3	N/A
4	Digital Input Ground Connection
5	Digital Input Connections
6	Digital Input Status Information LED
7	System Running LED
8	System Power LED
9	ID Assign Switch
10	Expansion Connector

1.1.3 General Device Specifications

SPECIFICATION	ITEM	DESCRIPTION
Electrical	Supply (Standard)	24 VDC (12-36VDC)
	Supply (Optional)	Over Expansion Bus
	Power	<10W
	Power Protection	Yes
Enviromental Conditions	Operating Temperature	-20...+60 C
	Storage Temperature	-40...+85 C
	Humidity	5...95 RH
	Operating Altitude	0...2000 m
ID Assign	Dip Switch	Between 0-15

1.2 CONNECTION DIAGRAM

1.2.1 Supply Connection

Supply:	12-36 VDC, Protected
Power:	<10 W

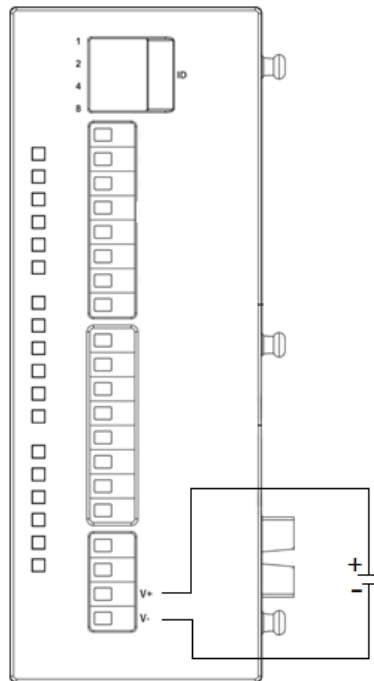

Figure 5 Digital Input Expansion Module Power Connection Diagram

1.2.2 Digital Inputs

Order Code:	XIO110-E0N-GD6-B2000	XIO110-E0N-GD0-B2000
Module Input:	8 Channel, PNP	16 Channel, PNP
Module Input Range:	0-50 VDC	
ON Voltage Range:	9-50 VDC	
OFF Voltage Level:	0-5 VDC	
Input Impedance:	3 Kohm>	
Isolation:	Optical	
OFF to ON Response:	20 us	
ON to OFF Response:	90 us	

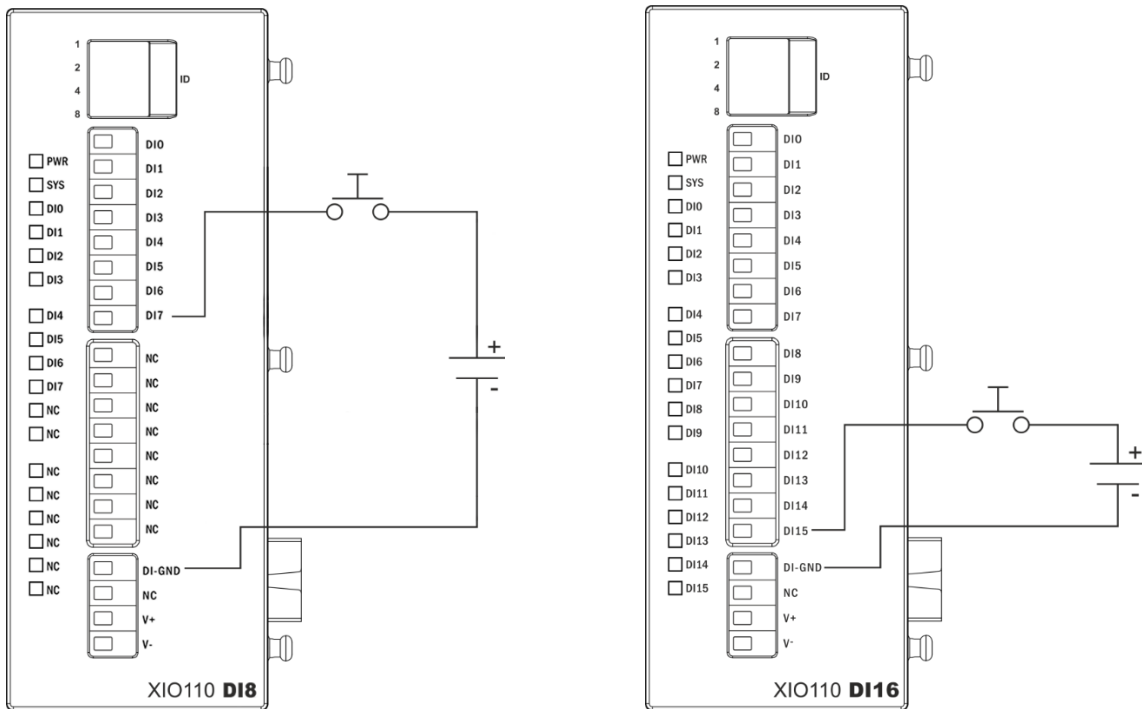

Figure 6 Digital Input Expansion Module Connection Diagram

2 XIO110 DIGITAL OUTPUT EXPANSION MODULES

2.1 GENERAL INFORMATION

2.1.1 GD7 Board Type(8 Digital Output) Physical Interfaces

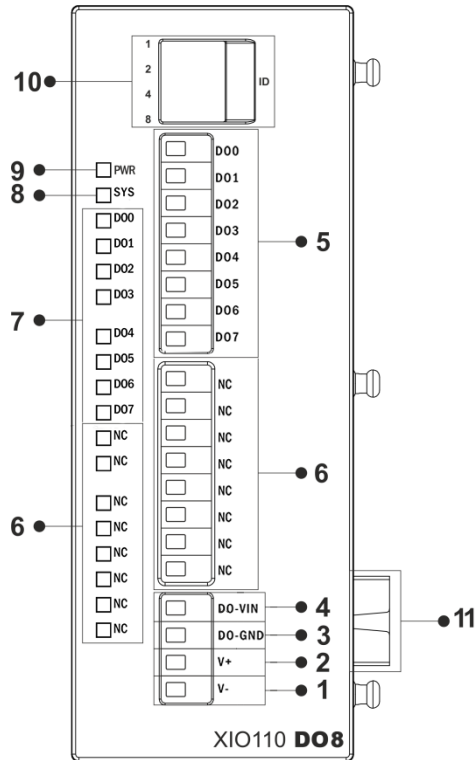

Figure 7 GD7 Board Type Connector and Physical Interfaces

1	Device Power (V-) Connection
2	Device Power (V+) Connection
3	Digital Output Ground Connection
4	Digital Output Supply Connection
5	Digital Output Connections
6	N/A
7	Digital Output Status Information LED
8	System Running LED
9	System Power LED
10	ID Assigning Switch
11	Expansion Connector

2.1.2 GD1 Board Type(16 Digital Output) Physical Interfaces

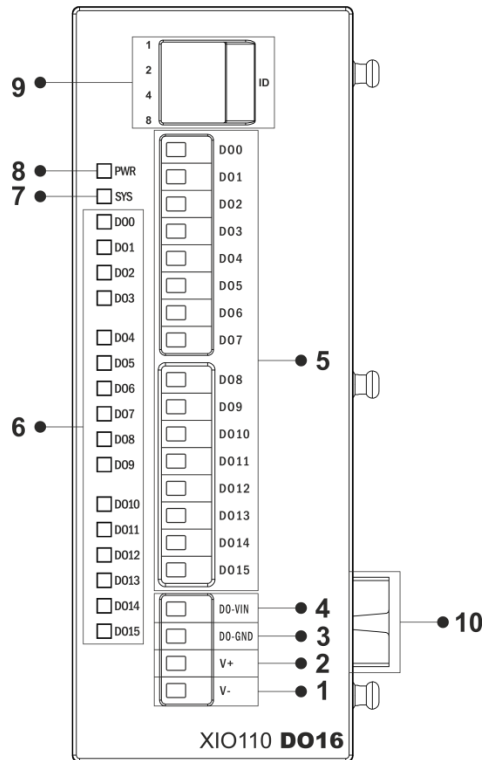

Figure 8 GD1 Board Type Connector and Physical Interfaces

1	Device Power (V-) Connection
2	Device Power (V+) Connection
3	Digital Output Ground Connection
4	Digital Output Supply Connection
5	Digital Output Connections
6	Digital Output Status Information LED
7	System Running LED
8	System Power LED
9	ID Assigning Switch
10	Expansion Connector

2.1.3 General Device Specifications

SPECIFICATION	ITEM	DESCRIPTION
Electrical	Supply (Standard)	24 VDC (12-36VDC)
	Supply (Optional)	Over Expansion Bus
	Power	<10W
	Power Protection	Yes
Enviromental Conditions	Operating Temperature	-20...+60 C
	Storage Temperature	-40...+85 C
	Humidity	5...95 RH
	Operating Altitude	0...2000 m
ID Assign	Dip Switch	Between 0-15

2.2 CONNECTION DIAGRAM

2.2.1 Supply Connection

Supply:	12-36 VDC, Protected
Power:	<10 W

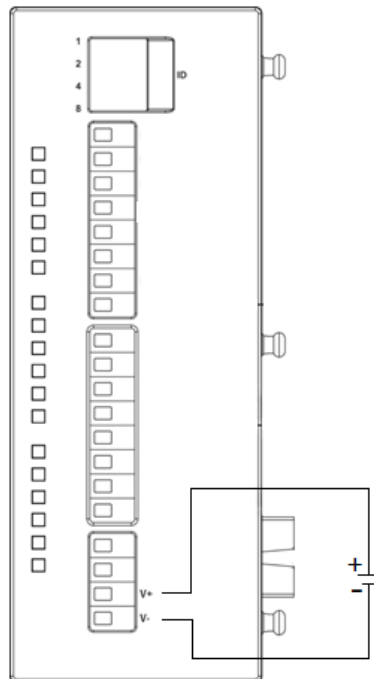

Figure 9 Digital Output Expansion Module Power Connection Diagram

2.2.2 Digital Outputs

Order Code:	XIO110-E0N-GD7-B4000	XIO110-E0N-GD1-B4000
Module Output:	8 Channel, Mosfet Output	16 Channel, Mosfet Output
Module Output Type:	PNP Transistor	
Module Output Range:	12-36 VDC	
Module Output Current:	2 A @ 30 VDC	
Module Output GND Common:	1 GND (16 Point/ Common)	
Isolation:	Optical	

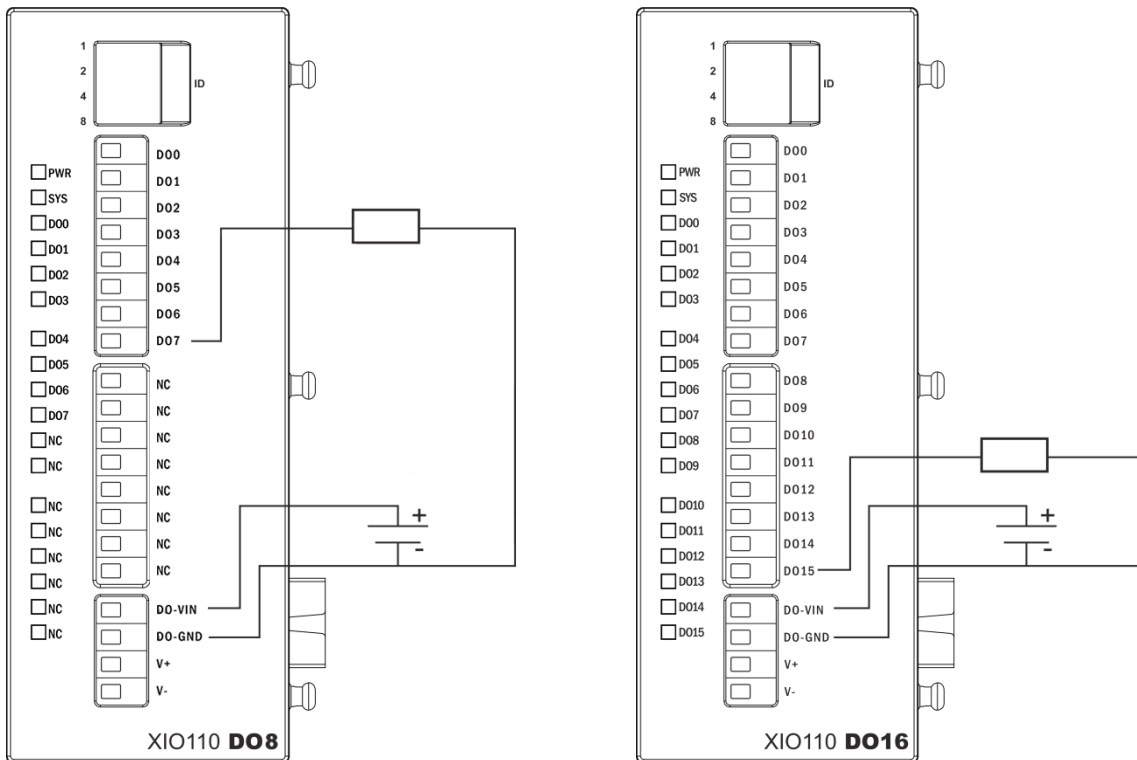

Figure 10 Digital Output Expansion Module Connection Diagram

3 XIO110 DIGITAL INPUT OUTPUT EXPANSION MODULES

3.1 GENERAL INFORMATION

3.1.1 GD8 Board Type(8 Digital Input, 8 Digital Output) Physical Interfaces

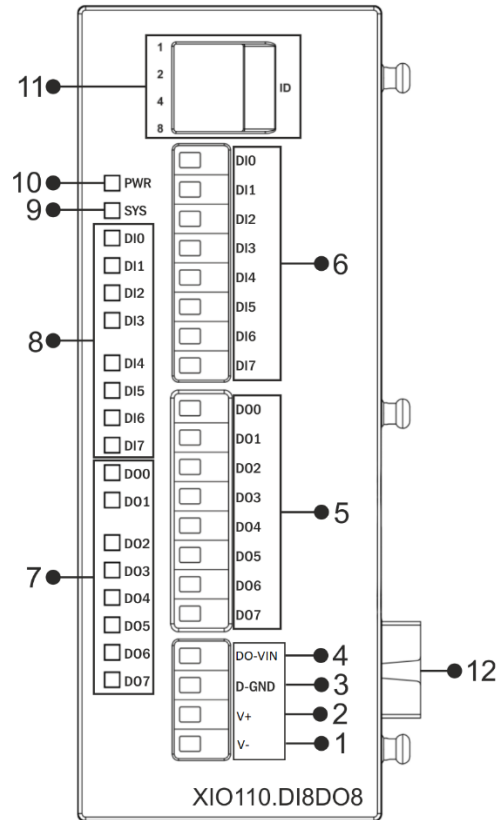

Figure 11 GD8 Board Type Connector and Physical Interfaces

1	Device Power (V-) Connection
2	Device Power (V+) Connection
3	Digital Input/Output Ground Connection
4	Digital Output Supply Connection
5	Digital Output Connections
6	Digital Input Connections
7	Digital Output Status Information LED
8	Digital Input Status Information LED
9	System Running LED
10	System Power LED
11	ID Assigning Switch
12	Expansion Connector

3.1.2 General Device Specifications

SPECIFICATION	ITEM	DESCRIPTION
Electrical	Supply (Standard)	24 VDC (12-36VDC)
	Supply (Optional)	Over Expansion Bus
	Power	<10W
	Power Protection	Yes
Enviromental Conditions	Operating Temperature	-20...+60 C
	Storage Temperature	-40...+85 C
	Humidity	5...95 RH
	Operating Altitude	0...2000 m
ID Assign	Dip Switch	Between 0-15

3.2 CONNECTION DIAGRAM

3.2.1 Supply Connection

Supply:	12-36 VDC, Protected
Power:	<10 W

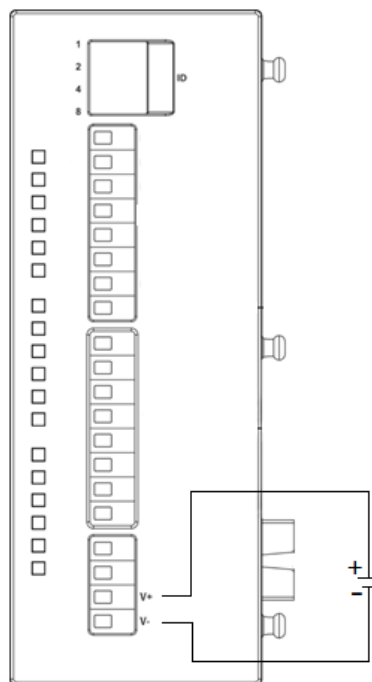

Figure 12 Digital Input Output Expansion Module Power Connection Diagram

3.2.2 Digital Input and Outputs

Order Code:	XIO110-E0N-GD8-B6000
-------------	----------------------

Module Input:	8 Channel, PNP
Module Input Range:	0-50 VDC
ON Voltage Range:	9-50 VDC
OFF Voltage Level:	0-5 VDC
Input Impedance:	3 Kohm>
Isolation:	Optical
OFF to ON Response:	20 us
ON to OFF Response:	90 us

Module Output:	8 Channel, Mosfet Output
Module Output Type:	PNP Transistor
Module Output Range:	12-36 VDC
Module Output Current:	2 A @ 30 VDC
Module Output GND Common:	1 GND (8 Point/ Common)
Isolation:	Optical

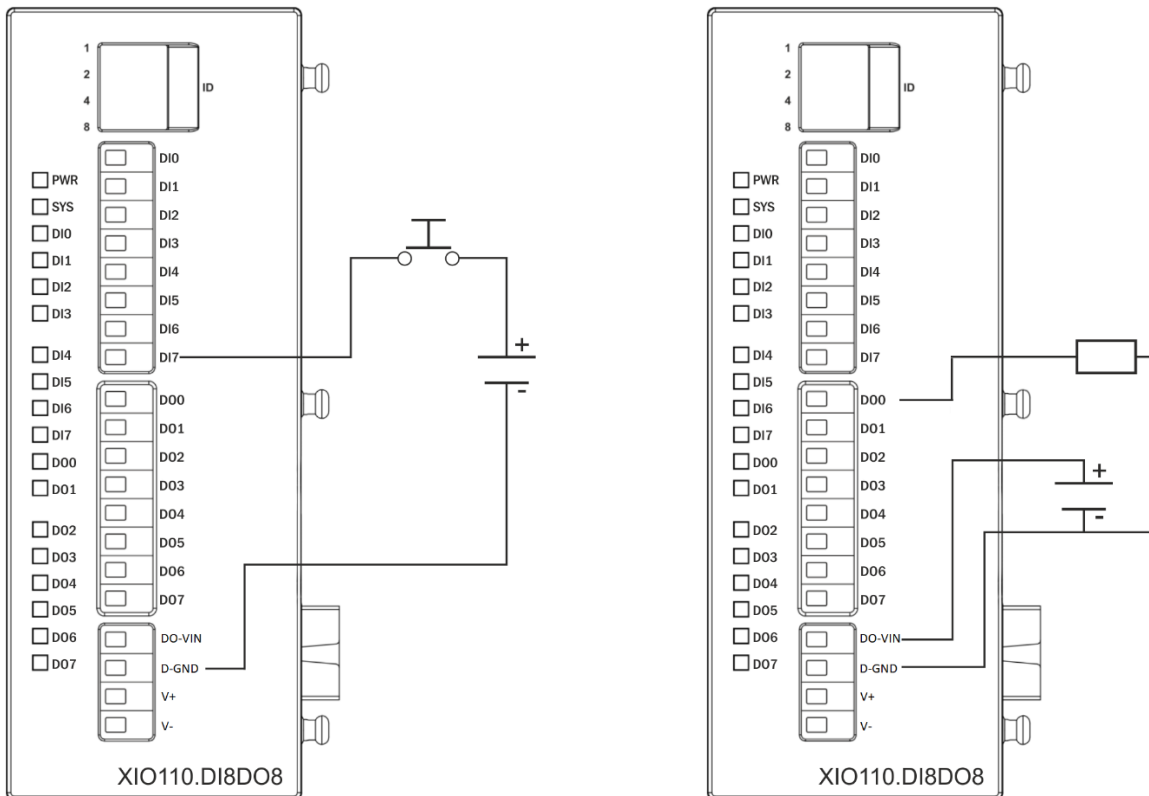

Figure 13 Digital Input Output Expansion Module Connection Diagram

4 XIO110 ANALOG INPUT EXPANSION MODULES

4.1 GENERAL INFORMATION

4.1.1 GD2 Board Type(8 Analog Input) Physical Interfaces

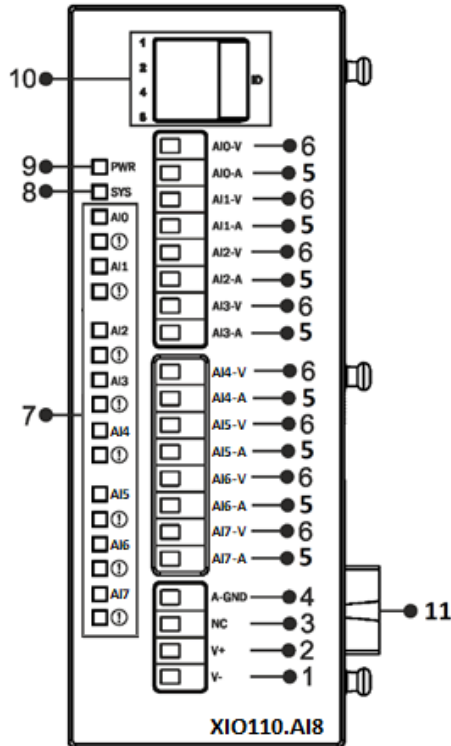

Figure 14 GD2 Board Type Connector and Physical Interfaces

1	Device Power (V-) Connection
2	Device Power (V+) Connection
3	N/A
4	Analog Input Ground Connection
5	Analog Input Current Connections
6	Analog Input Voltage Connections
7	Analog Input Status Information LED
8	System Running LED
9	System Power LED
10	ID Assigning Switch
11	Expansion Connector

4.1.2 General Device Specifications

SPECIFICATION	ITEM	DESCRIPTION
Electrical	Supply (Standard)	24 VDC (12-36VDC)
	Supply (Optional)	Over Expansion Bus
	Power	<10W
	Power Protection	Yes
Enviromental Conditions	Operating Temperature	-20...+60 C
	Storage Temperature	-40...+85 C
	Humidity	5...95 RH
	Operating Altitude	0...2000 m
ID Assign	Dip Switch	Between 0-15

4.2 CONNECTION DIAGRAM

4.2.1 Supply Connection

Supply:	12-36 VDC, Protected
Power:	<10 W

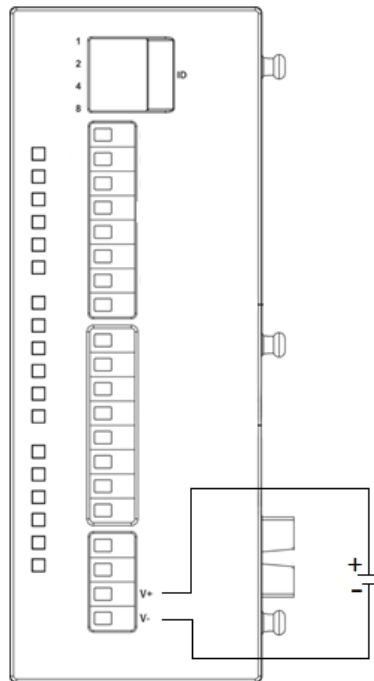

Figure 15 Analog Input Expansion Module Power Connection Diagram

4.2.2 Analog Inputs

Order Code:	XIO110-E0N-GD2-B0401
Module Input Type:	Current, Voltage
Analog Input:	8 Channel
Resolution:	16 Bit
Analog Input Accuracy:	%1 Accuracy
Current Input Range:	0-20 mA, 4-20 mA
Voltage Input Range:	0-10 V
Analog Input GND Common:	1 GND (8 Point / Common)
Isolation:	Optical Isolation Expansion Bus

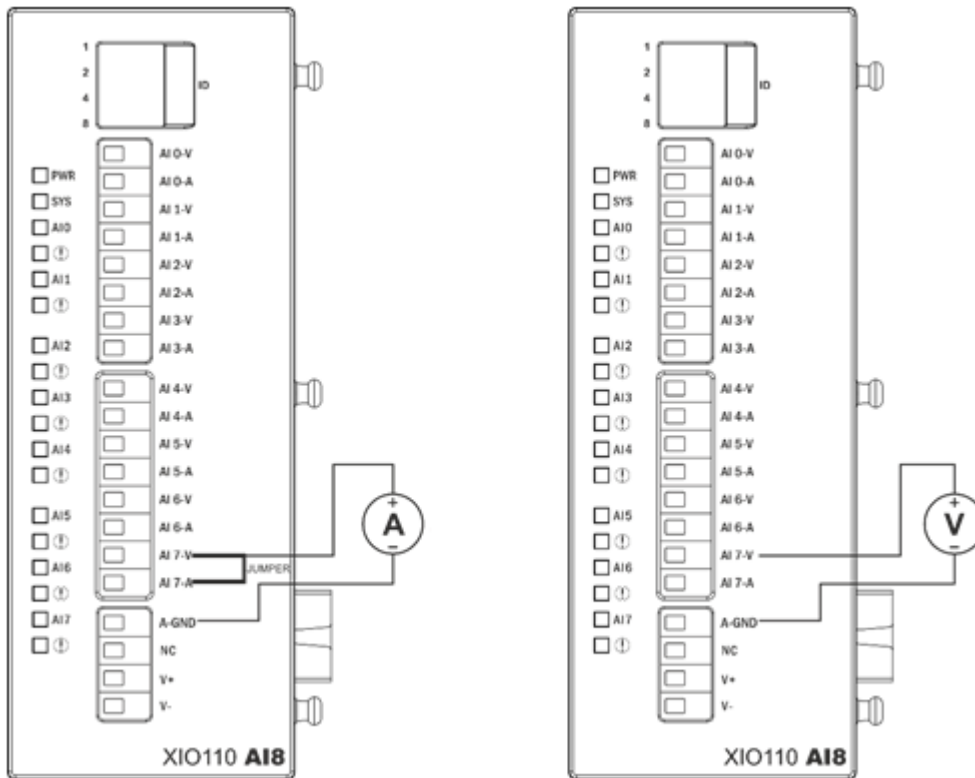

Figure 16 Analog Input Expansion Module Connection Diagram

5 XIO110 ANALOG OUTPUT EXPANSION MODULES

5.1 GENERAL INFORMATION

5.1.1 GD3 Board Type(8 Analog Output) Physical Interfaces

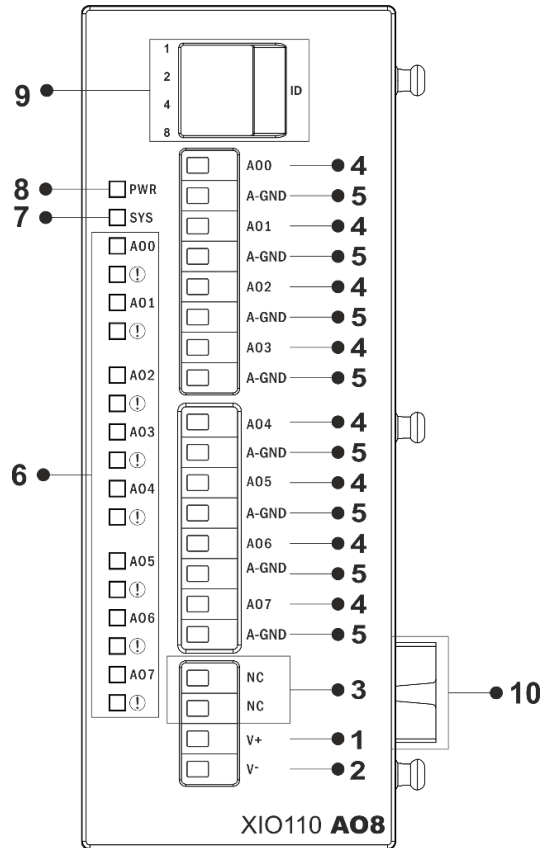

Figure 17 GD3 Board Type Connector and Physical Interfaces

1	Device Power (V-) Connection
2	Device Power (V+) Connection
3	N/A
4	Analog Output Connection
5	Analog Output Ground Connection
6	Analog Output Status Information LED
7	System Running LED
8	System Power LED
9	ID Assigning Switch
10	Expansion Connector

5.1.2 General Device Specifications

SPECIFICATION	ITEM	DESCRIPTION
Electrical	Supply (Standard)	24 VDC (12-36VDC)
	Supply (Optional)	Over Expansion Bus
	Power	<10W
	Power Protection	Yes
Enviromental Conditions	Operating Temperature	-20...+60 C
	Storage Temperature	-40...+85 C
	Humidity	5...95 RH
	Operating Altitude	0...2000 m
ID Assign	Dip Switch	Between 0-15

5.2 CONNECTION DIAGRAM

5.2.1 Supply Connection

Supply:	12-36 VDC, Protected
Power:	<10 W

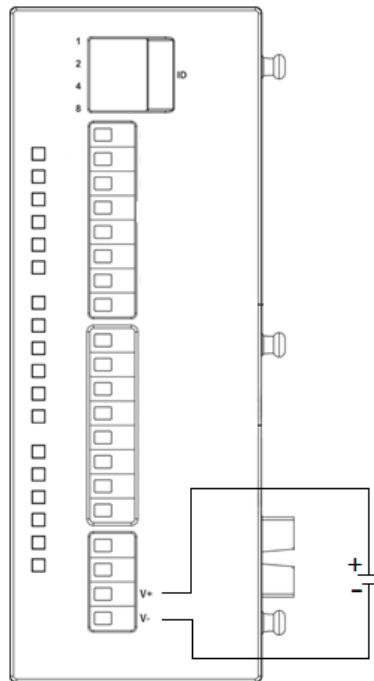

Figure 18 Analog Output Expansion Module Power Connection Diagram

5.2.2 Analog Outputs

Order Code:	XIO110-E0N-GD3-B0000	XIO110-E0N-GD3-B0800
Module Output Type:	Current	Voltage
Analog Output:	8 Channel	
Resolution:	12 Bit	
Analog Output Accuracy:	%1 Accuracy	
Current Output Range:	0-20 mA, 4-20 mA	
Voltage Output Range:	0-10 V	
Analog Output GND Common:	8 GND (8 Point / Common)	
Isolation:	Optical Isolation Expansion Bus	

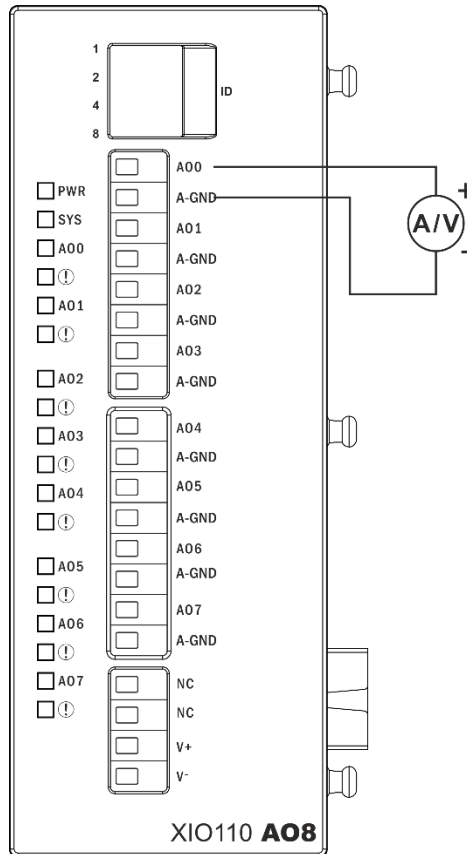

Figure 19 Analog Output Expansion Module Connection Diagram

6 XIO110 ANALOG INPUT OUTPUT EXPANSION MODULES

6.1 GENERAL INFORMATION

6.1.1 GD9 Board Type(4 Analog Input, 4 Analog Output) Physical Interfaces

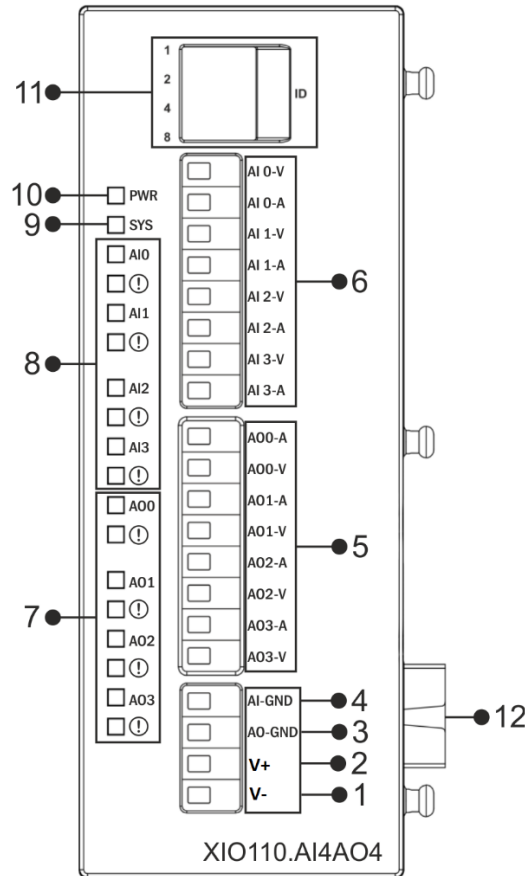

Figure 20 GD9 Board Type Connector and Physical Interfaces

1	Device Power (V-) Connection
2	Device Power (V+) Connection
3	Analog Output Ground Connection
4	Analog Input Ground Connection
5	Analog Output Connection
6	Analog Input Connection
7	Analog Output Status Information LED
8	Analog Input Status Information LED
9	System Running LED
10	System Power LED
11	ID Assigning Switch
12	Expansion Connector

6.1.2 General Device Specifications

SPECIFICATION	ITEM	DESCRIPTION
Electrical	Supply (Standard)	24 VDC (12-36VDC)
	Supply (Optional)	Over Expansion Bus
	Power	<10W
	Power Protection	Yes
Enviromental Conditions	Operating Temperature	-20...+60 C
	Storage Temperature	-40...+85 C
	Humidity	5...95 RH
	Operating Altitude	0...2000 m
ID Assign	Dip Switch	Between 0-15

6.2 CONNECTION DIAGRAM

6.2.1 Supply Connection

Supply:	12-36 VDC, Protected
Power:	<10 W

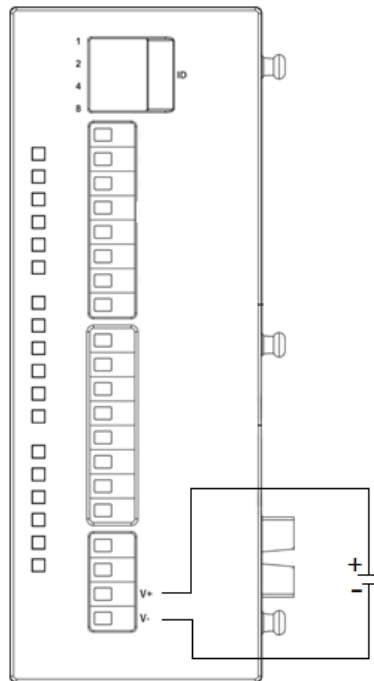

Figure 21 Analog Input Output Expansion Module Power Connection Diagram

6.2.2 Analog Input and Outputs

Order Code:	XIO110-E0N-GD9-B0000	XIO110-E0N-GD9-B0900
Analog Input/Output Type:	Current	Voltage

Analog Input:	4 Channel
Resolution:	12 Bit
Analog Input Accuracy:	%1 Accuracy
Current Input Range:	0-20 mA, 4-20 mA
Voltage Input Range:	0-10 V
Analog Input GND Common:	1 GND (4 Point / Common)
Isolation:	Optical Isolation Expansion Bus

Analog Output:	4 Channel
Resolution:	12 Bit
Analog Output Accuracy:	%1 Accuracy
Current Output Range:	0-20 mA, 4-20 mA
Voltage Output Range:	0-10 V
Analog Output GND Common:	1 GND (4 Point / Common)
Isolation:	Optical Isolation Expansion Bus

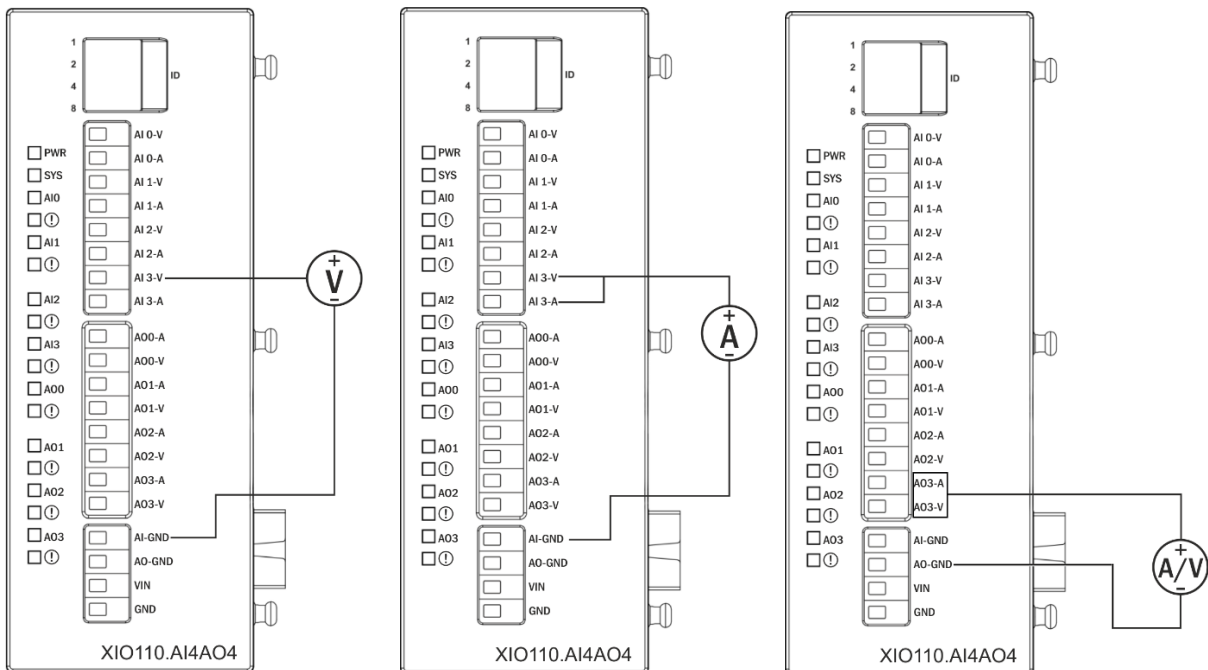

Figure 22 Analog Input Output Expansion Module Connection Diagram

7 XIO110 RTD INPUT(PT100/PT1000) EXPANSION MODULES

7.1 GENERAL INFORMATION

7.1.1 GD4 Board Type(6 RTD Input) Physical Interfaces

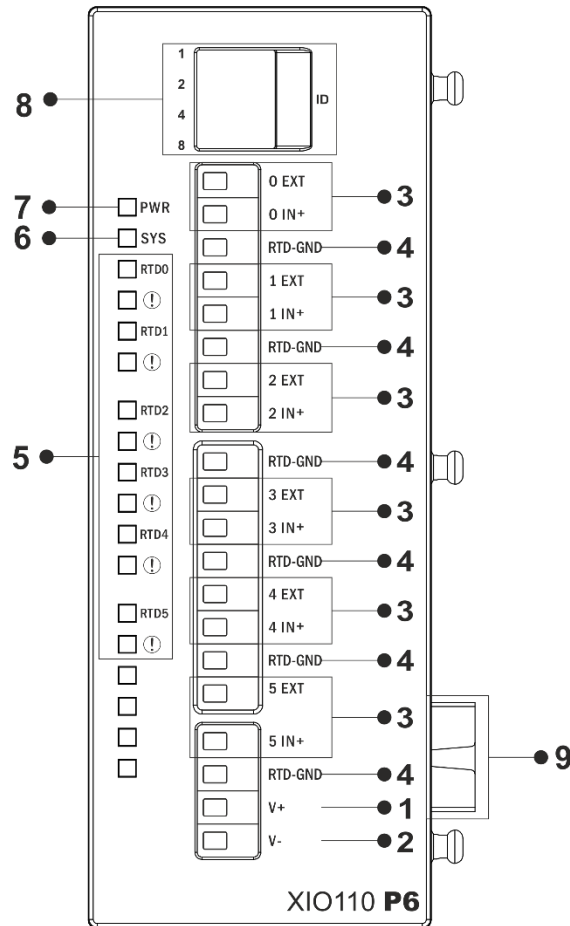

Figure 23 GD4 Board Type Connector and Physical Interfaces

1	Device Power (V+) Connection
2	Device Power (V-) Connection
3	RTD Input Connection
4	RTD Input Ground Connection
5	RTD Status Information LED
6	System Running LED
7	System Power LED
8	ID Assigning Switch
9	Expansion Connector

7.1.2 General Device Specifications

SPECIFICATION	ITEM	DESCRIPTION
Electrical	Supply (Standard)	24 VDC (12-36VDC)
	Supply (Optional)	Over Expansion Bus
	Power	<10W
	Power Protection	Yes
Enviromental Conditions	Operating Temperature	-20...+60 C
	Storage Temperature	-40...+85 C
	Humidity	5...95 RH
	Operating Altitude	0...2000 m
ID Assign	Dip Switch	Between 0-15

7.2 CONNECTION DIAGRAM

7.2.1 Supply Connection

Supply:	12-36 VDC, Protected
Power:	<10 W

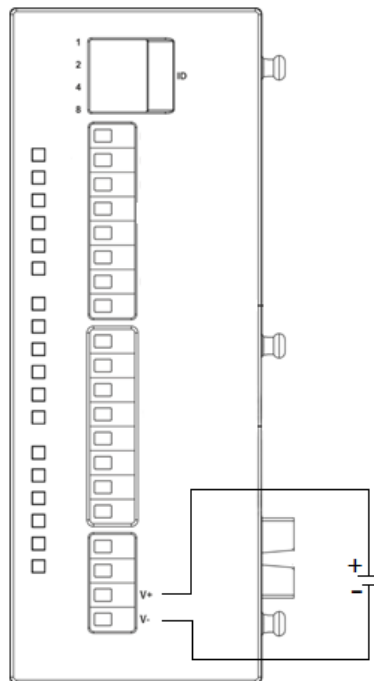

Figure 24 RTD Input Expansion Module Power Connection Diagram

7.2.2 RTD Inputs

Order Code:	XIO110-E0N-GD4-B0000	XIO110-E0N-GD4-B0010
RTD Input Type:	PT1000	PT100
RTD Input:	6 Channel	
RTD Input Resolution:	12 Bit	
RTD Input Accuracy:	%1 Accuracy	
RTD Input GND Connection:	6 GND (6 Point / Common)	
Temperature Range:	-200...400 C	

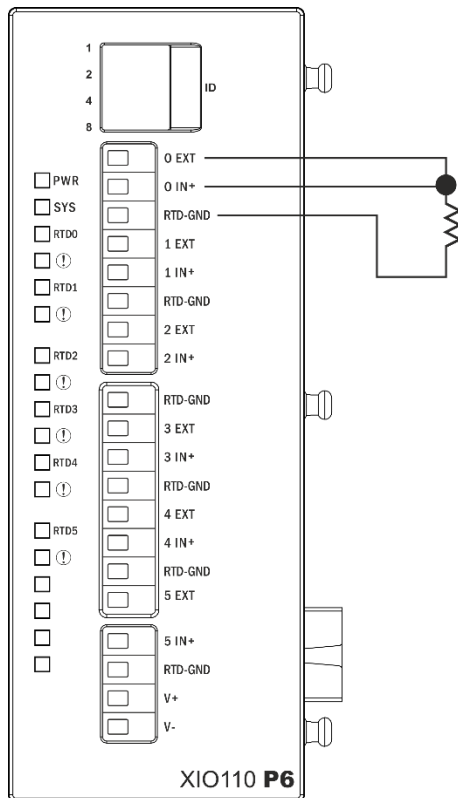

Figure 25 RTD Input Expansion Module Connection Diagram

8 XIO110 DALI EXPANSION MODULES

8.1 GENERAL INFORMATION

8.1.1 GDA Board Type (1 DALI Port) Physical Interfaces

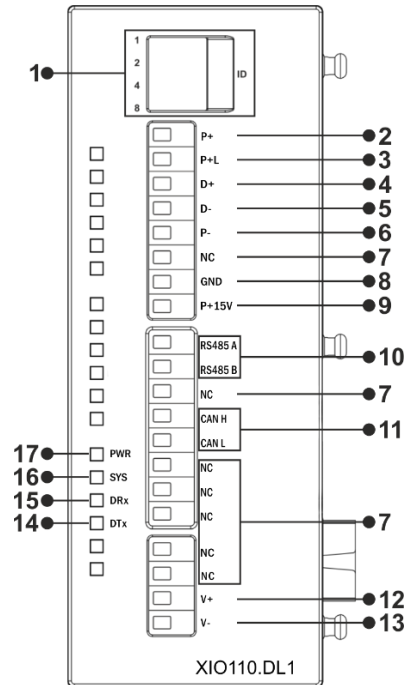

Figure 26 GDA Board Type Connector and Physical Interfaces

1	ID Assignment Switch
2	Current Unlimited Power Connection
3	DALI Current Limit Power Output (+) Connection
4	DALI Current Limited Power (+) Connection
5	DALI Current Limited Power (-) Connection
6	DALI Current Limited Power Output (-) Connection
7	N/A
8	No Current Limit 15 V Gnd Connection
9	Current Unlimited 15 V Connection
10	RS485 Connections
11	CANBUS Communication Connection
12	Device Power (V+) Connection
13	Device Power (V-) Connection
14	DALI Protocol Data Send LED
15	DALI Protocol Data Receive LED
16	System Working LED
17	System Energized LED

8.1.2 General Device Specifications

SPECIFICATION	ITEM	DESCRIPTION
Electrical	Supply (Standard)	24 VDC (12-36VDC)
	Supply (Optional)	Over Expansion Bus
	Power	<10 W
	Power Protection	Yes
Enviromental Conditions	Operating Temperature	-20...+60 C
	Storage Temperature	-40...+85 C
	Humidity	5...95 RH
	Operating Altitude	0...2000 m
ID Assign	Dip Switch	Between 0-15

8.2 CONNECTION DIAGRAM

8.2.1 Supply Connection

Supply:	12-36 VDC, Protected
Power:	<10 W

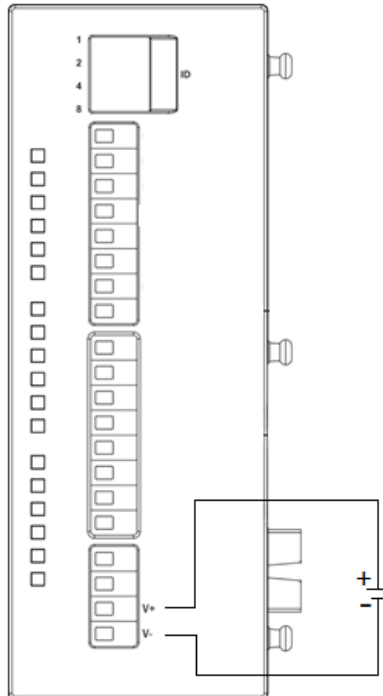

Figure 27 DALI Expansion Module Power Connection Diagram

8.2.2 DALI Current-Limited Power Connection

Order Code:	XIO110-E0N-GDA-B0000
DALI BUS:	1 Port
DALI Connection Max. Device Count:	64
DALI BUS Power Supply:	300 mA @ 15 V DC

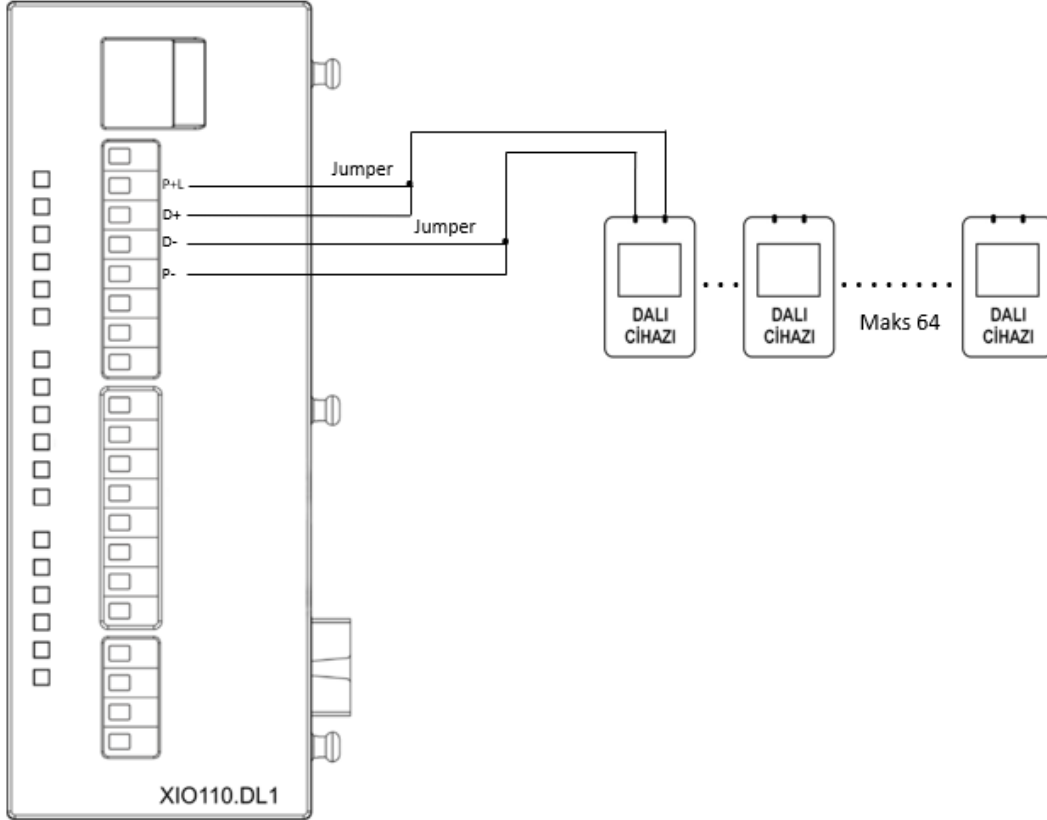

Figure 28 DALI Expansion Module Connection Diagram

8.2.3 DALI Current-Limited Power Output Connection

DALI BUS:	1 Port
DALI Connection Max. Device Count:	64
DALI BUS Power Supply:	300 mA @ 15 V DC

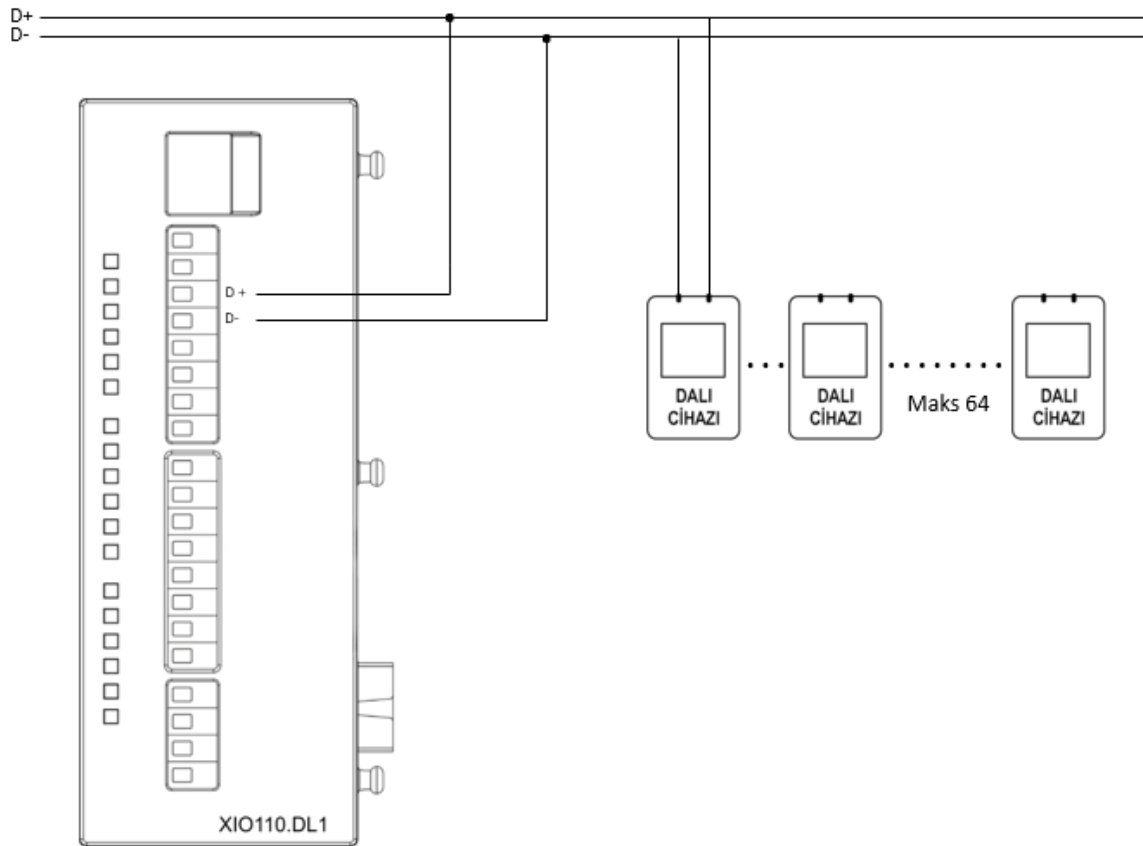

Figure 29 DALI Current-Limited Power Output Connection

9 XIO110 END MODULE

9.1 GENERAL INFORMATION

9.1.1 GDx Board Type Physical Interfaces

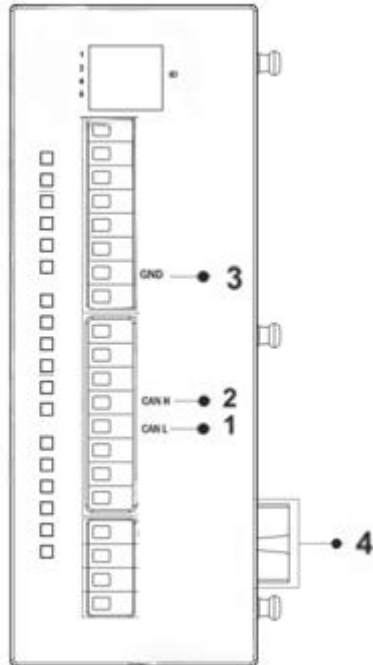

Figure 30 GDx Board Type Connector and Physical Interfaces

1	Canbus L Connection
2	Canbus H Connection
3	Canbus GND Connection
4	Expansion Connector

9.1.2 General Device Specifications

It is used to complete the communication line between expansion modules located on two different rails on the panel.

SPECIFICATION	ITEM	DESCRIPTION
Electrical	Supply:	The termination module does not require an external power supply.
	Max Cable Length to be Used Between Two End Modules:	2 m
	Type of Cable to be Used Between Two End Modules:	Shielded twisted pair (STP)

9.2 CONNECTION DIAGRAM

9.2.1 Supply Connection

As seen in Figure 31 and Figure 32, CANBUS connections can be established.

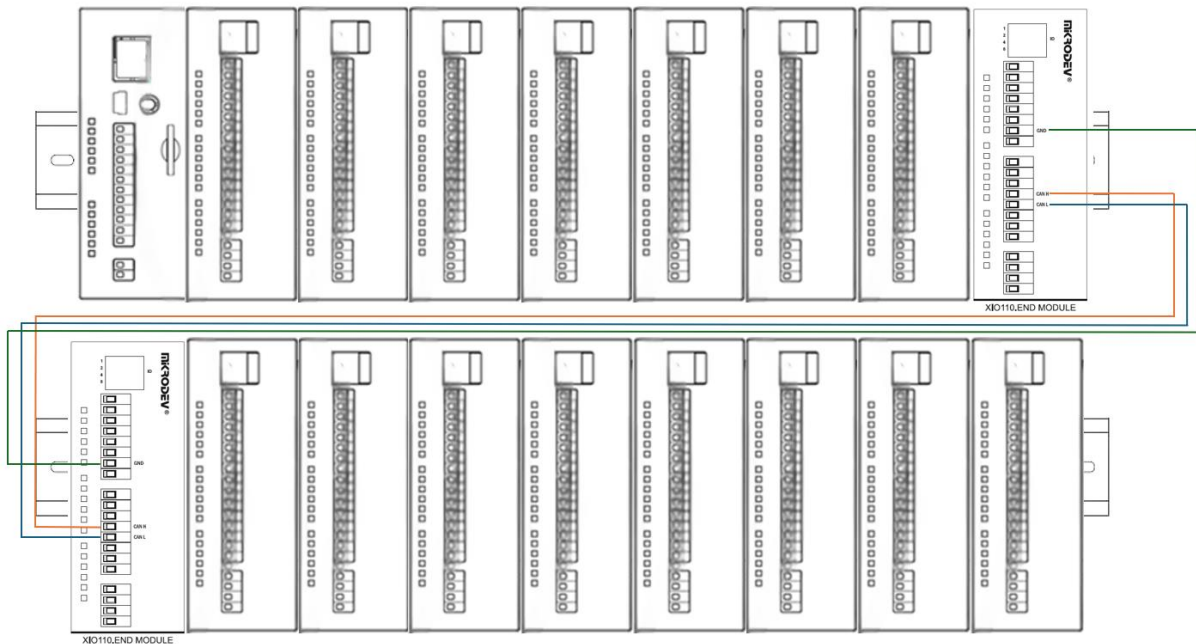

Figure 31 End Module Canbus Connection Diagram 1

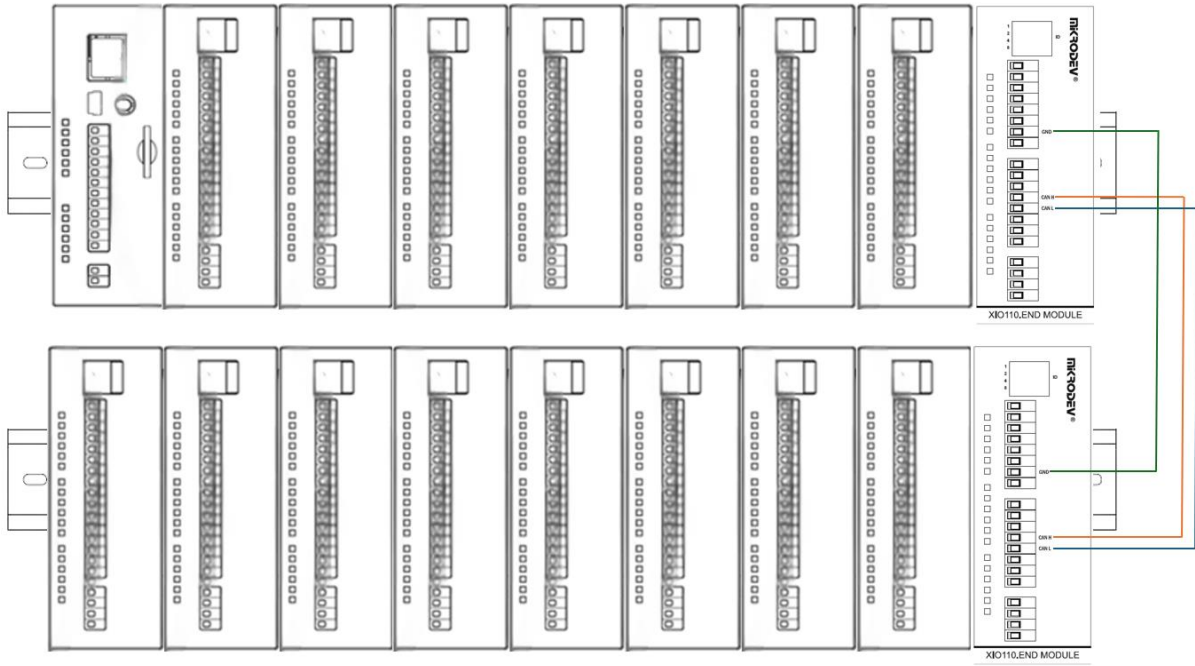

Figure 32 End Module Canbus Connection Diagram 2